



POWER BRAKE KIT

PBF-48, PBF-56, PBC-47, PBC-55

Kit Includes: Main bracket, Strut Rod, Stabilizer, Drive Rod assembly, Hardware kit
Additional Parts Required: Power Brake Booster and Master Cylinder – 74'-90' Mustang

1. Remove the stock master cylinder from its mounting bracket. Clean the mounting bracket and frame 16" to the rear of the mounting bracket (fig. 1)

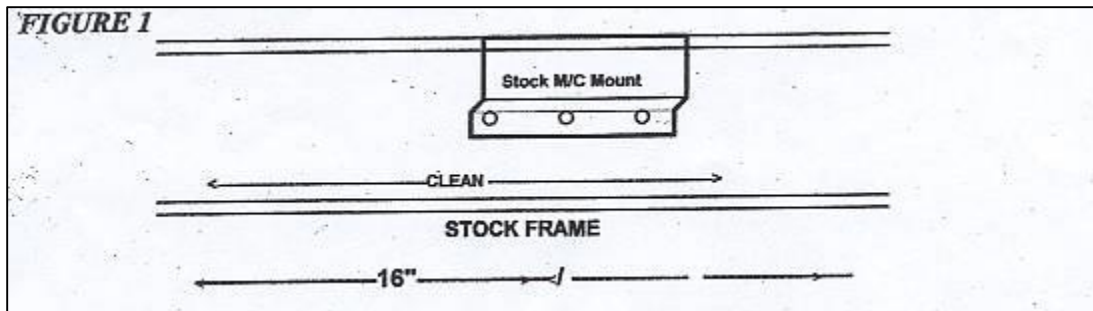

2. Place the main bracket from the No Limit kit into the frame, just behind the stock master cylinder mounting bracket. Using the bolts supplied, bolt the No Limit bracket into the stock mount (fig. 2)

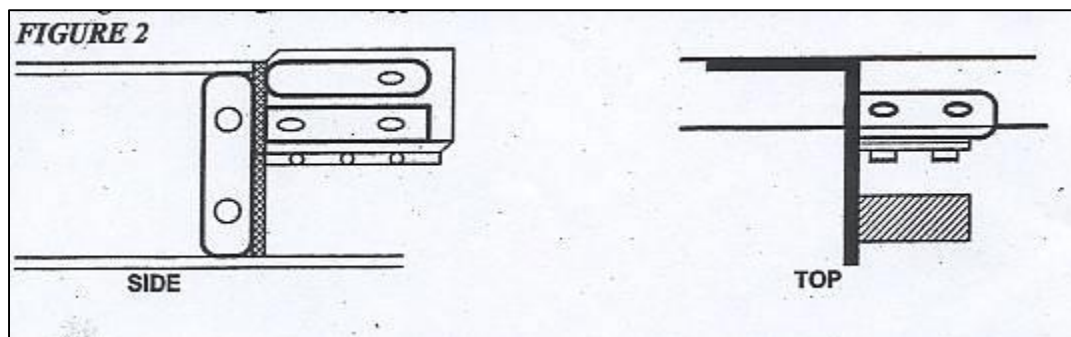

3. **BOLT-IN KITS.** Drill two holes through the frame, using the No Limit bracket as a guide, and bolt the bracket to the frame. **WELD-IN KITS.** Check to make sure that the bracket is square to the frame, then weld it in (1947-54 Chevy frames are tapered, so the bracket will not be square with the frame)
4. Bolt the Mustang Booster into the No Limit bracket.
5. **Drive Rod.** Place the stabilizer into the tower of the main bracket. Note – the stabilizer is offset, the bar should be set in so that it is as close to the frame as possible. Next, place the drive rod from the booster and stabilizer to the stock pedal (fig. 3)

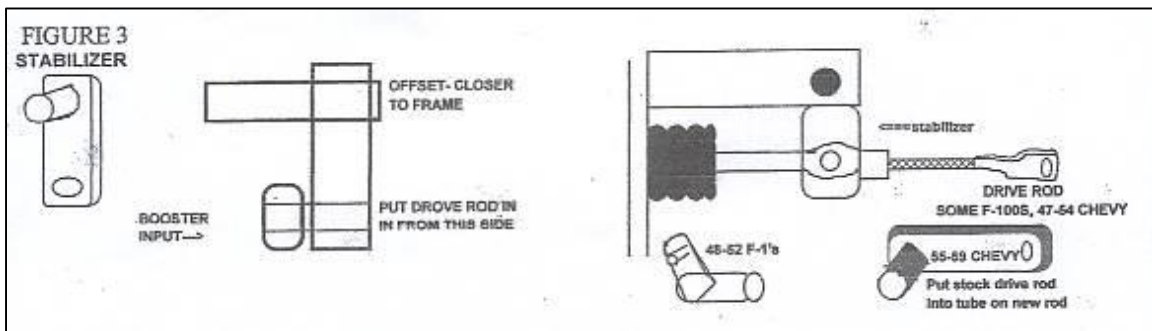

6. **Strut Rod.** This brace is added for strength. It is to attach to one of the booster studs and the frame. (fig. 4) Weld or bolt to frame.

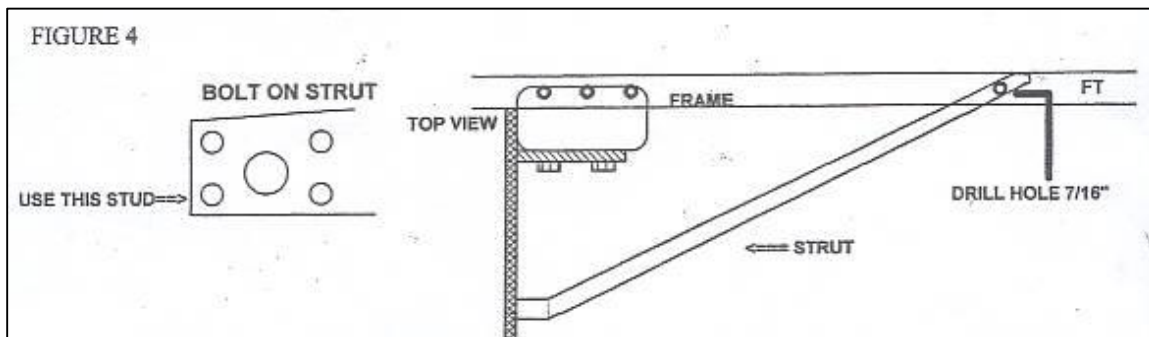

7. **FILLING THE MASTER.** There are two ways to go about this. A small fluid pump or **REMOTE FILLING.** By using some brass fittings threaded into the master cylinder it is possible to use a remote reservoir to fill the master cylinder.
8. **BRAKE LINES.** Keep is simple. The small pocket of the m/c is for the rear brakes. You may run the line straight to the rear. An adjustable proportioning valve is optional. The master cylinder is made for disk/ drum applications. If you have from drums, use a 10 lb. residual valve in the front to compensate for this.

FIGURE 5

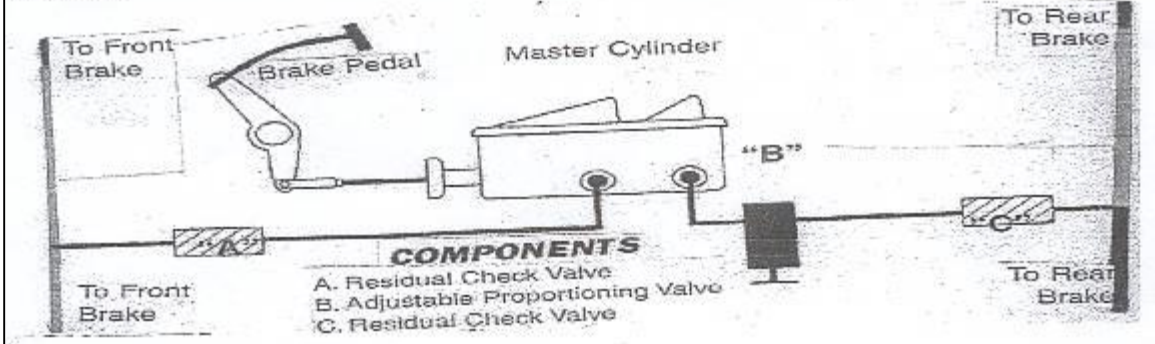

**POWER BRAKE INSTALLATION HINTS :
 47-59 Chevys**

***** Clean all of the parts first !!**

**** This will quiken reation time and shorten the required pedal movement.**

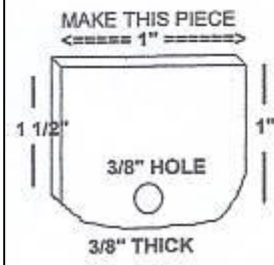
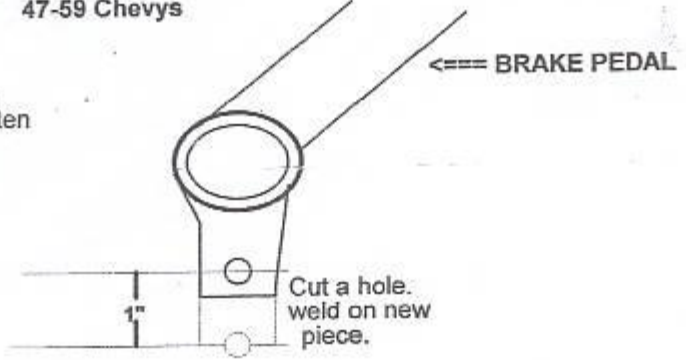

1953-56 FORD F-100

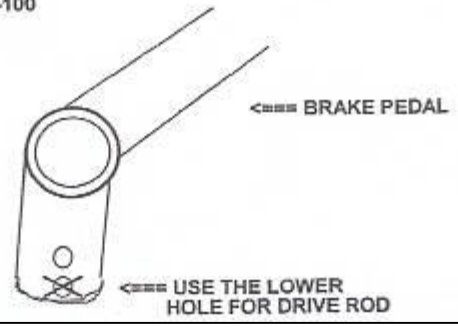

Always put the stock pedal return spring back in place !!!

48-52 F-1's and 53-56 F-100's BRAKE LIGHT SWITCH. Try one from a 55-59 Chevy p/u mech. Type firewall mounted. We sell them if you can't find one.