



SB-120/130 FRONT SWAY BAR

This kit **WILL** work with mono leaves, drop leaves, and drop axles.

NOTE: If you have a GM power steering kit that mounts outside the frame, you will have to trim and weld one mount for the sway bar. (SEE STEP # 4)

1. Left truck, place jack-stands under the front axle. It is important to keep the suspension loaded. Remove the front tires.
2. The sway bar mounts directly in front of the axle (FIGURE 1) using the mounting and U-bolts, fit the sway bar into place. Due to the shape of some axles, light grinding of the casting seam may be needed for proper U-bolt fit. The mounting plates should be about 5" inside of the springs. Snug up the bolts.
3. Lift the front ends of the bar so that the arms are parallel with the springs.
4. Assemble the end links and mounts onto the bar. Hold them straight up. Mark and drill holes into the frame. Measure, to make sure the brackets are the same height on both sides.
5. Check for any interference and tighten all bolts.
6. Re-mount the wheels and test drive the vehicle.

FIGURE #1

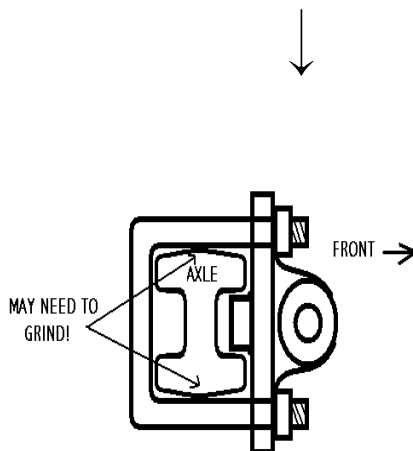

FIGURE #2

